

Flow sensor
Immersion sensor with integrated processor
FCS-N1/2A4P-ARX-B1151/115VAC

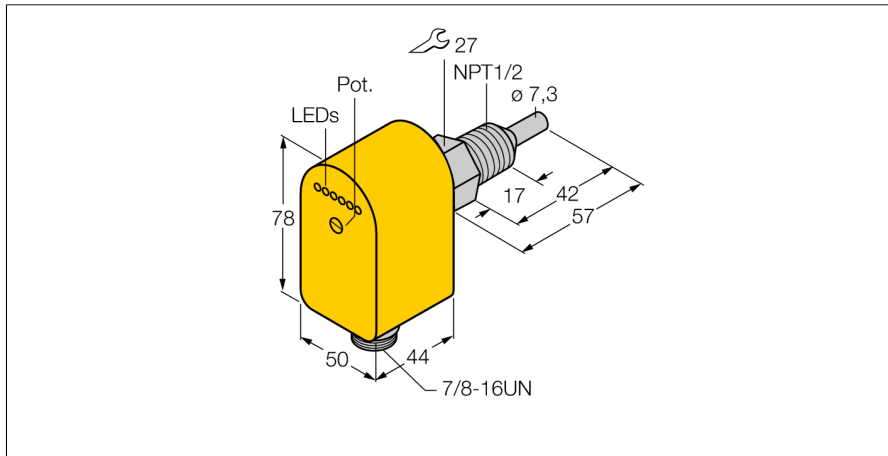

- Flow sensor for liquid media
- Calorimetric principle
- Adjustment via potentiometer
- LED band
- AC 5-wire, 98...132 VAC
- NO contact, relay output
- Plug-in device, 7/8"

Wiring diagram

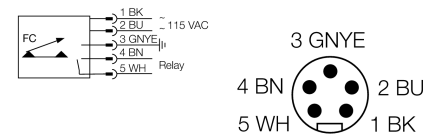

Type code	FCS-N1/2A4P-ARX-B1151/115VAC
Ident no.	6871025
Operating range water	1...150cm/s
Oil operating range	3...300 cm/s
Stand-by time	typ. 8 s (2...15 s)
Switch-on time	typ. 2 s (1...15 s)
Switch-off time	typ. 2 s (1...15 s)
Temperature jump, response time	max. 12 s
Temperature gradient	≤ 250 K/min
Medium temperature	- 20...80 °C
Operating voltage	98...132 VAC
Output function	Relay output, NO contact
Rated operational current	2 A
Short-circuit protection	no
AC switching voltage	250 VAC
DC switching voltage	60 VDC
Max. AC switching capacity	500 VA
Max. DC switching capacity	50 W
Housing material	plastic, PBT
Sensor material	stainless steel, AISI 316Ti
Max. tightening torque housing nut	100 Nm
Connection	male, 7/8"
Pressure resistance	100 bar
Process connection	NPT 1/2"
Switching state	LED chain green / yellow / red
Indication: Drop below setpoint	LED red
Indication: Setpoint reached	LED yellow
Indication: Setpoint exceeded	4 x LEDs green

Functional principle

Our insertion - flow sensors operate on the principle of thermodynamics. The measuring probe is heated by several °C as against the flow medium. When fluid moves along the probe, the heat generated in the probe is dissipated. The resulting temperature is measured and compared to the medium temperature. The flow status of every medium can be derived from the evaluated temperature difference. Thus TURCK's wear-free flow sensors reliably monitor the flow of gaseous and liquid media.