

BIM-IKE-Y1X W/KLI3

Magnetic Field Sensor – for pneumatic cylinders

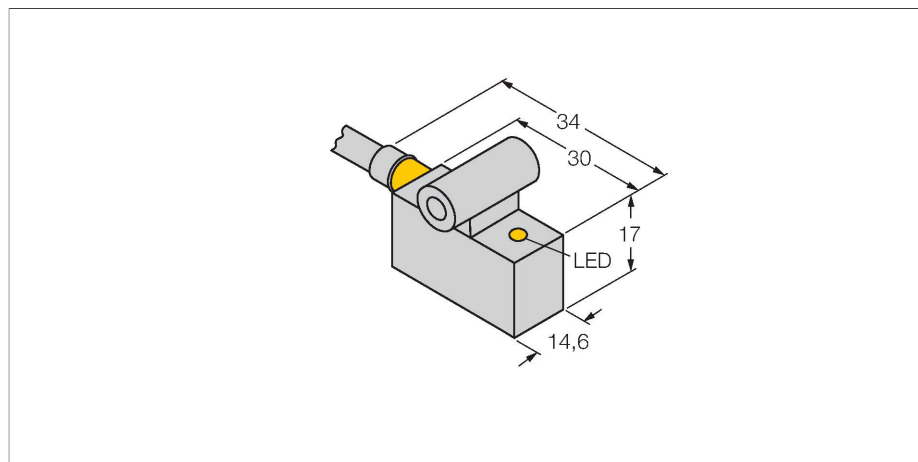

Features

- Rectangular, height 17 mm
- Active face in front
- Metal, GD-Zn
- Magnetic-inductive sensor
- DC 2-wire, nom. 8.2 VDC
- Output acc. to DIN EN 60947-5-6 (NAMUR)
- Cable connection
- ATEX category II 2 G, Ex zone 1
- ATEX category II 1 D, Ex zone 20
- SIL2 (Low Demand Mode) acc. to IEC 61508, PL c acc. to ISO 13849-1 at HFT0
- SIL3 (All Demand Mode) acc. to IEC 61508, PL e acc. to ISO 13849-1 with redundant configuration HFT1

Technical data

Type	BIM-IKE-Y1X W/KLI3
Ident. no.	1056490
Pass speed	≤ 10 m/s
Repeatability	≤ ± 0.1 mm
Temperature drift	≤ 0.1 mm
Hysteresis	≤ 1 mm
Ambient temperature	-25...+70 °C
Output function	2-wire, NAMUR
Switching frequency	1 kHz
Voltage	Nom. 8.2 VDC
Current consumption non-actuated	≤ 1.2 mA
Actuated current consumption	≥ 2.1 mA
Approval acc. to	KEMA 02 ATEX 1090X
Internal capacitance (C.)/inductance (L.)	150 nF/150 µH
Device marking	Ⓔ II 2 G Ex ia IIC T6 Gb / II 1 D Ex ia IIIC T95 °C Da (max. U _i = 20 V, I _i = 60 mA, P _i = 200 mW)
Design	Rectangular, IKE
Dimensions	30 x 14.6 x 17 mm
Housing material	Metal, GD-Zn
Active area material	Plastic, PA12-GF30
Electrical connection	Cable
Cable quality	Ø 5.2 mm, Blue, Lif9YYW, PVC, 2 m
Core cross-section	2 x 0.25 mm ²
Vibration resistance	55 Hz (1 mm)
Shock resistance	30 g (11 ms)
Protection class	IP67
MTTF	6198 years acc. to SN 29500 (Ed. 99) 40 °C

Wiring diagram

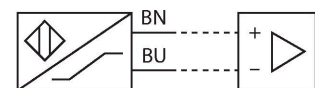

Functional principle

Magnetic field sensors are activated by magnetic fields and are especially suited for piston position detection in pneumatic cylinders. Based on the fact that magnetic fields can permeate non-magnetizable metals, it is possible to detect a permanent magnet attached to the piston through the aluminium wall of the cylinder.

Technical data

Mounting on the following profiles	.
Cylindrical design	○ ##
Switching state	LED, Yellow

Mounting instructions

Mounting instructions/Description

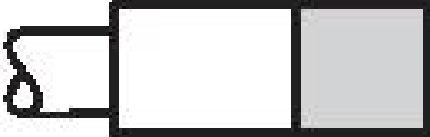

Accessories

KLI5Z **6971803**

Mounting bracket for mounting magnetic field sensors on tie-rod cylinders; cylinder diameter: 32...63 mm; material: Aluminum

KLI6Z **6971806**

Mounting bracket for mounting magnetic field sensors on tie-rod cylinders; cylinder diameter: 50...125 mm; material: Aluminum

KLI6 **6971805**

Mounting bracket for mounting magnetic field sensors on profile cylinders; cylinder diameter: 50...100 mm; material: Aluminum

KLI7 **6971810**

Mounting bracket for mounting magnetic field sensors on profile cylinders with external dovetail guide; cylinder diameter: 32...200 mm; material: Aluminum

KLI1 **69710**

Mounting bracket for mounting magnetic field sensors on tie-rod cylinders; cylinder diameter: 32...100 mm; material: Die-cast Zinc

KLI5 **6971802**

Mounting bracket for mounting magnetic field sensors on profile cylinders; cylinder diameter: 32...50 mm; material: Aluminum

KLI3

69712

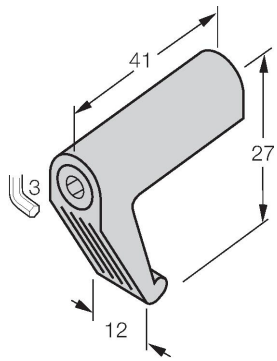

Mounting bracket for mounting magnetic field sensors on tie-rod cylinders; cylinder diameter: 63...160 mm; material: Die-cast Zinc

IMX12-DI01-2S-2T-0/24VDC

7580020

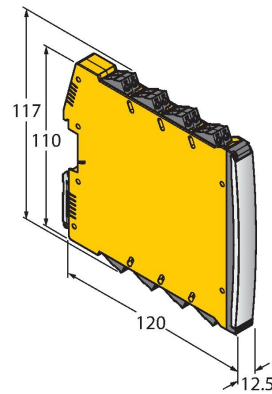

Isolating switching amplifier, 2-channel; SIL2 acc. to IEC 61508; Ex-proof version; 2 transistor outputs; input Namur signal; ON/OFF switchable monitoring of wire-break and short-circuit; toggle between NO/NC mode; signal doubling; removable screw terminals; 12.5 mm wide; 24 VDC power supply