

TURCK

Your Global Automation Partner

IMX12-TI... | IM12-TI... Temperature Transmitter

Contents

1	About this document	5
2	Scope	5
3	Safety Integrity Level	6
4	Product description	7
4.1	Safety function	8
4.2	Safety accuracy	8
4.3	Safe state	10
4.4	Alarm state	10
5	Safety-Planning	10
5.1	Architectural specifications	10
5.2	Assumption	11
5.3	FMEDA results	11
5.4	Examples for using the results	12
5.4.1	Probability of dangerous failure per hour (High Demand mode)	12
5.4.2	Average probability of dangerous failure on demand (Low Demand mode)	12
6	Operating instructions	13
6.1	General	13
6.2	Before Operation	15
6.3	Parameterization	16
6.3.1	Preparation	16
6.3.2	Parameters	17
6.3.3	Parameter-Check	25
6.4	Operation	25
6.5	After operation	25
7	Appendix: Connection and wiring diagrams	26
8	Appendix: Terms and abbreviations	29
9	Appendix: Failures	30
9.1	Resistance	30
9.2	TC	30
9.3	RTD	31
10	Appendix: Proof tests	32
11	Appendix: Document history	32
12	Appendix: Certificate	32



1 About this document

This safety manual contains all information that is required by users to operate the device in functional safety systems. Read this manual carefully before using the device.

This document addresses only functional safety according IEC 61508. Other aspects, such as intrinsic safety, are not considered.

All instructions must be followed in order to assure functional safety.

Always make sure that this is the latest version of the safety manual at www.turck.com. The English version is considered the definitive document. Care was taken in the production of the translations of this document. If there is any uncertainty in its interpretation, refer to the English version of the safety manual or contact TURCK directly.

2 Scope

This safety manual is valid for the following devices:

ID	Product Name	Number of Channels	Terminal Block Design	Power-Bridge-Connection	Intrinsic-Safety
7580504	IMX12-TI02-1TCURTDR-1I1R-CPR/24VDC	1	screw clamps	yes	yes
7580505	IMX12-TI02-1TCURTDR-1I1R-C0/24VDC	1	screw clamps	no	yes
7580506	IMX12-TI02-1TCURTDR-1I1R-CPR/24VDC/CC	1	spring type terminals	yes	yes
7580507	IMX12-TI02-1TCURTDR-1I1R-C0/24VDC/CC	1	spring type terminals	no	yes
7580508	IMX12-TI02-2TCURTDR-2I-CPR/24VDC	2	screw clamps	yes	yes
7580509	IMX12-TI02-2TCURTDR-2I-C0/24VDC	2	screw clamps	no	yes
7580510	IMX12-TI02-2TCURTDR-2I-CPR/24VDC/CC	2	spring type terminals	yes	yes
7580511	IMX12-TI02-2TCURTDR-2I-C0/24VDC/CC	2	spring type terminals	no	yes
7580512	IMX12-TI01-2RTDR-2I-CPR/24VDC	2	screw clamps	yes	yes
7580513	IMX12-TI01-2RTDR-2I-C0/24VDC	2	screw clamps	no	yes
7580514	IMX12-TI01-2RTDR-2I-CPR/24VDC/CC	2	spring type terminals	yes	yes
7580515	IMX12-TI01-2RTDR-2I-C0/24VDC/CC	2	spring type terminals	no	yes
7580525	IM12-TI02-1TCURTDR-1I1R-CPR/24VDC	1	screw clamps	yes	no
7580526	IM12-TI02-1TCURTDR-1I1R-C0/24VDC/CC	1	spring type terminals	no	no
7580527	IM12-TI02-1TCURTDR-1I1R-C0/24VDC	1	screw clamps	no	no
7580528	IM12-TI02-1TCURTDR-1I1R-CPR/24VDC/CC	1	spring type terminals	yes	no
7580529	IM12-TI02-2TCURTDR-2I-CPR/24VDC	2	screw clamps	yes	no
7580530	IM12-TI02-2TCURTDR-2I-CPR/24VDC/CC	2	spring type terminals	yes	no
7580531	IM12-TI02-2TCURTDR-2I-C0/24VDC/CC	2	spring type terminals	no	no
7580532	IM12-TI02-2TCURTDR-2I-C0/24VDC	2	screw clamps	no	no
7580533	IM12-TI01-2RTDR-2I-CPR/24VDC	2	screw clamps	yes	no
7580534	IM12-TI01-2RTDR-2I-C0/24VDC	2	screw clamps	no	no
7580535	IM12-TI01-2RTDR-2I-CPR/24VDC/CC	2	spring type terminals	yes	no
7580536	IM12-TI01-2RTDR-2I-C0/24VDC/CC	2	spring type terminals	no	no

In the following chapters the devices are divided

- IMX12-TI02-1TCURTD R-111R
- IMX12-TI02-2TCURTD R-2I
- IMX12-TI01-2RTD R-2I
- IM12-TI02-1TCURTD R-111R
- IM12-TI02-2TCURTD R-2I
- IM12-TI01-2RTD R-2I

3 Safety Integrity Level

This divces are related to a SIL of

SIL2

4 Product description

In the following chapter the individual variants are described:

IMX12-TI01-2RTDR-2I
IM12-TI01-2RTDR-2I

Dual-channel temperature transmitter

Input:

- RTDs according to IEC 60751, DIN 43760, GOST 6651-94 (2-, 3-, 4-wire)
- Resistors (0...5000 Ω) (2-, 3-, 4-wire)
- Adjustable via PC interface (PC-Connect)

Output

- Current output source / sink 0/4...20 mA
- Common alarm output (MOSFET), potential free

IMX12-TI02-2TCURTDR-2I
IM12-TI02-2TCURTDR-2I

Dual-channel temperature transmitter

Input:

- RTDs according to IEC 60751, DIN 43760, GOST 6651-94 (2-, 3-wire)
- Resistors (0...5000 Ω) (2-, 3-wire)
- Adjustable via PC interface (PC-Connect)
- Thermo couple according to IEC 60584, DIN 43710, GOST R 8.585-2001
- cold junction compensation internal, external or constant
- Low voltages (-150...+150 mV)

Output

- Current output source / sink 0/4...20 mA
- Common alarm output (MOSFET), potential free

IMX12-TI02-1TCURTDR-111R
IM12-TI02-1TCURTDR-111R

Single-channel temperature transmitter

Input:

- RTDs according to IEC 60751, DIN 43760, GOST 6651-94 (2-, 3-, 4-wire)
- Resistors (0...5000 Ω) (2-, 3-, 4-wire)
- Adjustable via PC interface (PC-Connect)
- Thermo couple according to IEC 60584, DIN 43710, GOST R 8.585-2001
- cold junction compensation internal, external or constant
- Low voltages (-150...+150 mV)

Output

- Current output source / sink 0/4...20 mA
- Common alarm output (MOSFET), potential free
- Relay output, change

4.1 Safety function

Variants	Safety Function
IMX12-TI01-2RTDR-2I IMX12-TI02-2TCURTDR-2I IM12-TI01-2RTDR-2I IM12-TI02-2TCURTDR-2I	The measured values at input [E ₁ , E ₂] are transmitted to the output [A ₁ A, A ₂ A] according to the parameterization within 10 s (local process safety time) observing the permissible safety accuracy.
IMX12-TI02-1TCURTDR-111R IM12-TI02-1TCURTDR-111R	The measured values at input [E ₁] are transmitted to the output [A ₁ A, A ₁ D] according to the parameterization within 10 s (local process safety time) observing the permissible safety accuracy.

The Power-Bridge is not part of the safety-function.

LEDs are not part of safety function.

Two devices must not be used for the same safety function, e.g. to increase the hardware fault tolerance to achieve a higher SIL.

The two channels on the 2-channel devices must not be used for the same safety function, e.g. to increase the hardware fault tolerance to achieve a higher SIL.

Only one input and one output are part of the safety function. Exception: Differential input mode. In this case, two input signals are combined.

The safety function is executed 5 s after power-on.

4.2 Safety accuracy

The safety accuracy Δ_{total} depends on the variant and its configuration.

In order to evaluate the safety accuracy for an individual configuration the following information is required:

Accuracy	Value
Δ_{TC}	see chapter „Appendix: Failures – TC“ on page 30
Δ_{RTD}	see chapter „Appendix: Failures – RTD“ on page 31
Δ_{Ohm}	see chapter „Appendix: Failures – Resistance“ on page 30

$$\Delta_{[AxA]} = 100\mu A / (16 \text{ mA} / (| \text{“measuring range start”} - \text{“measuring range end”} |))$$

$\Delta_{[AxA]}$ refers to the particular output $\Delta_{[A1A]}$ or $\Delta_{[A2A]}$.

IMX12-TI01-2RTDR-2I and IM12-TI01-2RTDR-2I

The safety accuracy Δ_{total} depends on the parameter “[E_x] assigned to [A_x]”:

Assignment [E] to [A]	Δ_{total}
[E ₁] → [A _x]	$\Delta_{[E1]} + \Delta_{[AxA]}$
[E ₂] → [A _x]	$\Delta_{[E2]} + \Delta_{[AxA]}$
[E ₁ - E ₂] → [A _x] [E ₂ - E ₁] → [A _x]	$\Delta_{[E1]} + \Delta_{[E2]} + \Delta_{[AxA]}$

$\Delta_{[E1]}$ and $\Delta_{[E2]}$ depend on the parameter "Measuring mode".

Measuring Mode	$\Delta_{[E1]}, \Delta_{[E2]}$	Unit
RTD	Δ_{RTD}	°C
Resistor	Δ_{Ohm}	Ω

IMX12-TI02-2TCURTDR-2I and IM12-TI02-2TCURTDR-2I

The safety accuracy Δ_{total} depends on the parameter "[E_x] assigned to [A_x]":

Assignment [E] to [A]	Δ_{total}
[E ₁] → [A _x]	$\Delta_{[E1]} + \Delta_{[AxA]}$
[E ₂] → [A _x]	$\Delta_{[E2]} + \Delta_{[AxA]}$
[E ₁ - E ₂] → [A _x]	$\Delta_{[E1]} + \Delta_{[E2]} + \Delta_{[AxA]}$
[E ₂ - E ₁] → [A _x]	

$\Delta_{[E1]}$ and $\Delta_{[E2]}$ depend on the parameter "Measuring mode" and "CJC Mode" if applicable:

Measuring Mode	CJC Mode	$\Delta_{[E1]}, \Delta_{[E2]}$	Unit
TC	constant	Δ_{TC}	°C
TC	internal	$\Delta_{TC} + 2$	°C
TC	external	$\Delta_{TC} + \Delta_{RTD}$	°C
RTD	-	Δ_{RTD}	°C
Low voltage	-	0,175	mV
Resistor	-	Δ_{Ohm}	Ω

IMX12-TI02-1TCURTDR-1I1R and IM12-TI02-1TCURTDR-1I1R

The safety accuracy Δ_{total} depends on the parameter "[E_x] assigned to [A_x]":

Assignment [E] to [A]	Δ_{total}
[E ₁] → [A ₁ A]	$\Delta_{total} = \Delta_{[E1]} + \Delta_{[AxA]}$
[E ₂] → [A ₁ D]	$\Delta_{total} = \Delta_{[E1]}$

$\Delta_{[E1]}$ depends on the parameter "Measuring mode" and "CJC Mode" if applicable:

Measuring Mode	CJC Mode	$\Delta_{[E1]}, \Delta_{[E2]}$	Unit
TC	constant	Δ_{TC}	°C
TC	internal	$\Delta_{TC} + 2$	°C
TC	external	$\Delta_{TC} + \Delta_{RTD}$	°C
RTD	-	Δ_{RTD}	°C
Low voltage	-	0,175	mV
Resistor	-	Δ_{Ohm}	Ω

4.3 Safe state

IMX12-TI02-1TCURTDR-111R
 IMX12-TI02-2TCURTDR-2I
 IMX12-TI01-2RTDR-2I
 IM12-TI02-1TCURTDR-111R
 IM12-TI02-2TCURTDR-2I
 IM12-TI01-2RTDR-2I
 IMX12-TI02-1TCURTDR-111R
 IM12-TI02-1TCURTDR-111R

The safe state is defined as the output reaching the user defined threshold value.

The safe state is defined as the output is de-energized.

4.4 Alarm state

Internal diagnostics are provided in order to detect random hardware failures that result in a failure of the function. If a failure is detected the device goes into the alarm state. The time between the occurrence of the failure and the time to achieve the alarm state is less than 10 s. The device remains in alarm state as long as the failure persists, at least for 2 s.

IMX12-TI02-1TCURTDR-111R
 IMX12-TI02-2TCURTDR-2I
 IMX12-TI01-2RTDR-2I
 IM12-TI02-1TCURTDR-111R
 IM12-TI02-2TCURTDR-2I
 IM12-TI01-2RTDR-2I
 IMX12-TI02-1TCURTDR-111R
 IM12-TI02-1TCURTDR-111R

The alarm state is defined as the output is less than 3.6mA or greater than 21mA.

The alarm state is defined as the output is de-energized.

5 Safety-Planning

This chapter provides information for planning a safety-related loop.

The device is not specified for a certain application. Make sure that the data provided in this chapter is valid for your target application.

Special application-specific factors may cause the premature wear of the device and must be taken into consideration when planning systems; take special measures to compensate for a lack of experience based values, e.g. through implementation of shorter test intervals. The suitability for specific applications must be assessed by considering the particular overall safety-related system with regard to the requirements of IEC 61508.

Safety-planning must only be carried out by trained and qualified personnel. If there is any doubt contact TURCK directly.

5.1 Architectural specifications

Due to architectural considerations the following characteristics are specified:

Type	B
HFT	0

Experience has shown that the useful lifetime often lies within a range of 8 to 12 years. It can be significantly less if elements are operated near to their specification limits. However, it can be extended by appropriate measures.

For example, heavy temperature fluctuations could potentially decrease the useful lifetime, as constant temperature below 40 °C could potentially increase the useful lifetime.

For the relay outputs (cos phi = 1, I = 6A AC) the useful lifetime is 8 to 12 years or 30.000 switching cycles.

5.2 Assumption

- Failure rates are constant for 10 years, wear out mechanisms are not included.
- Propagation of failures is not relevant.
- External power supply failure rates are not included.
- All components that are not part of the safety function and cannot influence the safety function (feedback immune) are excluded.
- Only one input and one output are part of the safety function.

5.3 FMEDA results

The following safety characteristic are results of FMEDA.

	λ_{SD}	λ_{SU}	λ_{DD}	λ_{DU}	λ_{AU}	No effect	SFF
IMX12-TI01-2RTDR-2I	0 FIT	0 FIT	803 FIT	51 FIT	12 FIT	360 FIT	94 %
IMX12-TI02-2TCURTD-2I							
IM12-TI01-2RTDR-2I							
IM12-TI02-2TCURTD-2I							
Output: Analog							
Assignment [E] to [A]: Differential input mode							
IMX12-TI01-2RTDR-2I	0 FIT	0 FIT	555 FIT	28 FIT	8 FIT	294 FIT	95 %
IMX12-TI02-2TCURTD-2I							
IMX12-TI02-1TCURTD-111R							
IM12-TI01-2RTDR-2I							
IM12-TI02-2TCURTD-2I							
IM12-TI02-1TCURTD-111R							
Output: Analog							
IMX12-TI02-1TCURTD-111R	0 FIT	178 FIT	343 FIT	44 FIT	8 FIT	270 FIT	92 %
IM12-TI02-1TCURTD-111R							
Output: Relay							

The stated Safe Failure Fraction (SFF) is for reference only. The complete subsystem will need to be evaluated to determine the overall SSF.

The failure rates used in this analysis are the basic failure rates from the Siemens standard SN 29500 based on the average ambient temperature of components of 40 °C.

“No effect” is a failure mode of a component that plays part in implementing the safety function but is neither a safe nor a dangerous failure. According to IEC 62061 it would be possible to classify the “No effect” failures as “Safe Undetected” failures. Not doing so represents the worst-case.

For analog outputs a λ_{DD} failure is defined as a failure that is dangerous but is detected by internal diagnostics and causes the output the output signal to go to the maximum output current (> 21 mA) or minimum output current (< 3,6 mA).

5.4 Examples for using the results

5.4.1 Probability of dangerous failure per hour (High Demand mode)

The sum of the diagnostic test interval and the time to achieve the specified safe/alarm state is less than 10 s. The ratio of the diagnostic test rate to the demand rate shall equal or exceed 100.

	PFH
IMX12-TI01-2RTDR-2I IM12-TI01-2RTDR-2I	5.01E-08 1/h
IMX12-TI02-2TCURTD-2I IM12-TI02-2TCURTD-2I	5.01E-08 1/h
IMX12-TI02-1TCURTD-1I1R (analog output) IM12-TI02-1TCURTD-1I1R (analog output)	2.83E-08 1/h
IMX12-TI02-1TCURTD-1I1R (digital output) IM12-TI02-1TCURTD-1I1R (digital output)	4.41E-08 1/h

5.4.2 Average probability of dangerous failure on demand (Low Demand mode)

With the FMEDA results and the values specified in the following table the average frequency of dangerous failure can be calculated as an example:

T ₁	8760 h
MTTR	24 h

	PFDavg
IMX12-TI01-2RTDR-2I IM12-TI01-2RTDR-2I	2.98E-04
IMX12-TI02-2TCURTD-2I IM12-TI02-2TCURTD-2I	2.98E-04
IMX12-TI02-1TCURTD-1I1R (analog output) IM12-TI02-1TCURTD-1I1R (analog output)	1.71E-04
IMX12-TI02-1TCURTD-1I1R (digital output) IM12-TI02-1TCURTD-1I1R (digital output)	2.53E-04

6 Operating instructions

6.1 General

- ▶ The application program in the safety logic solver is configured according to NAMUR NE43 to detect under-range and over-range failures of the 4...20 mA output signal, and does not automatically trip on these failures; therefore these failures have been classified as dangerous detected failures.
- ▶ The device must not stay in safe state longer than 24 h. If the cause of entering the safe state was not corrected the device must be replaced.
- ▶ The user must detect currents < 3.6 mA and > 21 mA and maintain the safe state of the system.
- ▶ The device must be registered online: www.turck.com/SIL
- ▶ The device must only be carried out, fitted, installed, operated, commissioned and maintained by trained and qualified personnel.
- ▶ The device is not specified for a certain application. Make sure that application-specific aspects are considered.
- ▶ Data from other documents, e.g. data sheets, is not valid for functional safety operation. Devices must be used in cabinets in a typical industrial field environment only. The following restrictions describe the operation and storage conditions:

- ▶ Ensure that the environment complies with the following ratings

Minimum ambient temperature	-25 °C
Maximum ambient temperature	70 °C
Minimum storage temperature	-40 °C
Maximum storage temperature	80 °C
Maximum air humidity	95 %
Minimum air pressure	80 kPa
Maximum air pressure	110 kPa

- ▶ The average temperature over a long period of time directly on the exterior sidewall of the housing must be maximum 40 °C.
- The temperature on the exterior sidewall of the housing can deviate considerably from the temperature in the control cabinet.
- The temperature on the exterior sidewall of the housing must be observed in a steady state.
- In case the temperature on the exterior sidewall of the housing is higher, the failure rates from „5.3 FMEDA results“ on page 11 must be adjusted:
For a higher average temperature of 60 °C on the exterior sidewall of the housing, the failure rates are multiplied by an experience factor of 2.5.
- ▶ Ensure that sufficient heat dissipation is provided.
- ▶ Protect the device from radiated heat and severe temperature fluctuations.
- ▶ Protect the device from dust, dirt, moisture, shock, vibration, chemical stress, increased radiation and other environmental influences.
- ▶ Ensure a degree of protection of at least IP20 according to IEC 60529 at the mounting location.
- ▶ Ensure that the electromagnetic stress does not increase the requirements of IEC 61326-3.1.

- ▶ If there is a visible error, e.g. defective housing the device must not be used.
- ▶ During operation of the device, surface temperatures may occur that could lead to burns if touched.
- ▶ The device must not be repaired. If problems occur with regard to functional safety, TURCK must be notified immediately and the device must be returned immediately to:

TURCK GmbH
Witzlebenstraße 7
45472 Mülheim an der Ruhr
Germany

6.2 Before Operation

- ▶ Fasten the device to a rail according EN 60715 (TH35) as follows:

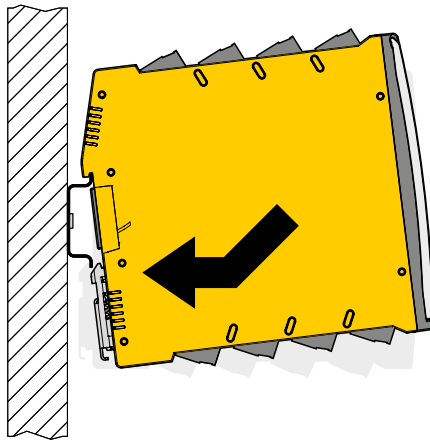

Fig. 1: Fasten the device

- ▶ Connect cables according to the wiring diagrams in „Appendix: Connection and wiring diagrams“ on page 26.
- ▶ Use cables with Terminal cross section
 - rigid: 0.2 mm² to 2.5 mm² or
 - flexible 0.2 mm² to 2.5 mm²
- ▶ When wiring with stranded wires: Fix the wiring ends with ferrules.

Connection via screw terminals:

- ▶ Insert the stripped cable ends (7 mm) in the guides of the cable glands.
- ▶ Fasten the screws with a screwdriver (max. tightening torque 0.5 Nm)

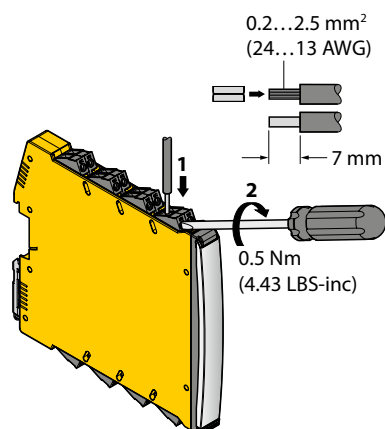

Fig. 2: Connection with screw terminals

Connection with spring-type terminals:

- ▶ Push the opening lever with a suitable screwdriver.
- ▶ Insert the stripped cable ends (7 mm) in the guides of the spring-type terminals.
- ▶ Pull the screwdriver to fix the cable ends

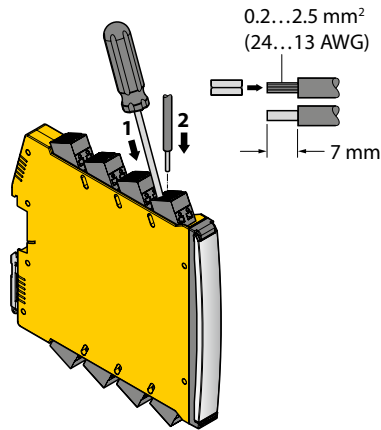

Fig. 3: Connection with spring-type terminals

- ▶ Make sure that only suitable equipment, e.g. sensors, are connected to the device (see „Appendix: Connection and wiring diagrams“ on page 26).
- ▶ Make sure that a suitable power supply with the following characteristic is used:

Minimum voltage	10 VDC
Maximum voltage	30 VDC
Minimum Power	4 W

The relay outputs shall be protected by a fuse that limits the current to 2A to avoid contact welding.

6.3 Parameterization

6.3.1 Preparation

For parameterization the following parts are required in addition to a PC with a suitable operating system:

Part name	Article number	Description
USB-2-IOL-002	6825482	IO-Link master 1.1 with integrated USB port for connection of IMX-device and PC
IOL-COM/3M	7525110	IO-Link communication cable

The following software is required. The software can be downloaded at www.turck.com.

Name	Description
PACTware	FDT frame application
USB-2-IOL-0002 DTM	Device Type Manager for IO-Link master 1.1
IODD Interpreter	The IODD interpreter is used to implement IODDs in FDT frame applications
Device specific IODD	The IO Device Description contains information about the devices` identity, parameters and process data.

Setup according to the manuals in order to connect and parameterize the IMX device.

6.3.2 Parameters

The user must select the parameters suitable for its safety application.

Input

The following figure illustrates the dependence of the parameters. Other parameters are required depending on the previously selected parameters. Selection options for parameters not located on a route marked with arrows are not relevant.

IMX12-TI02-1TCURTDR-111R
IM12-TI02-1TCURTDR-111R

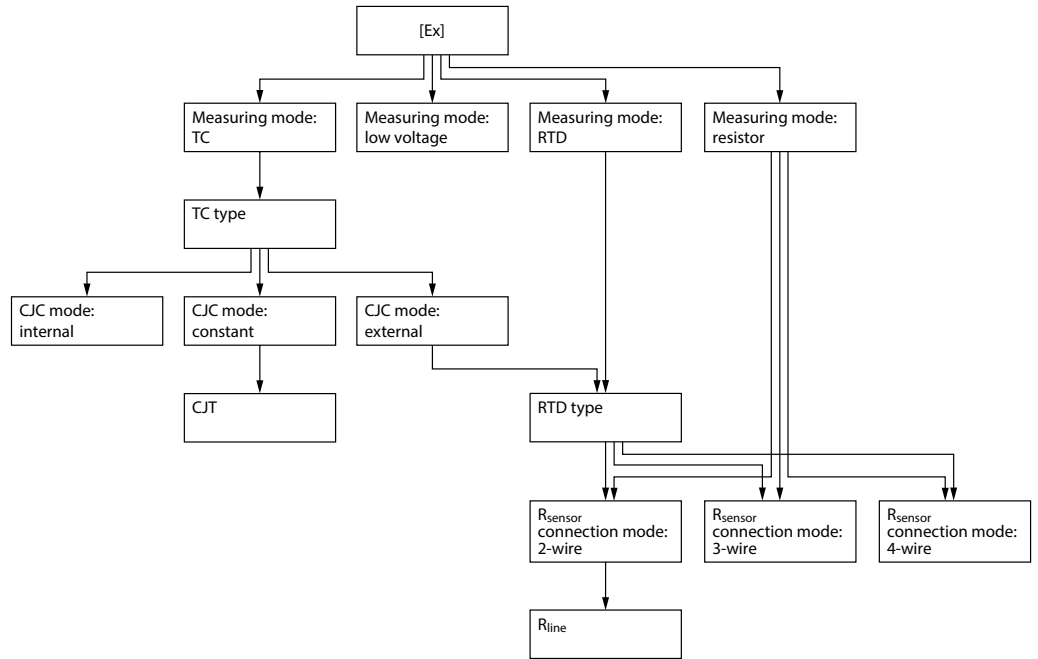

IMX12-TI02-2TCURTDR-2I
IM12-TI02-2TCURTDR-2I

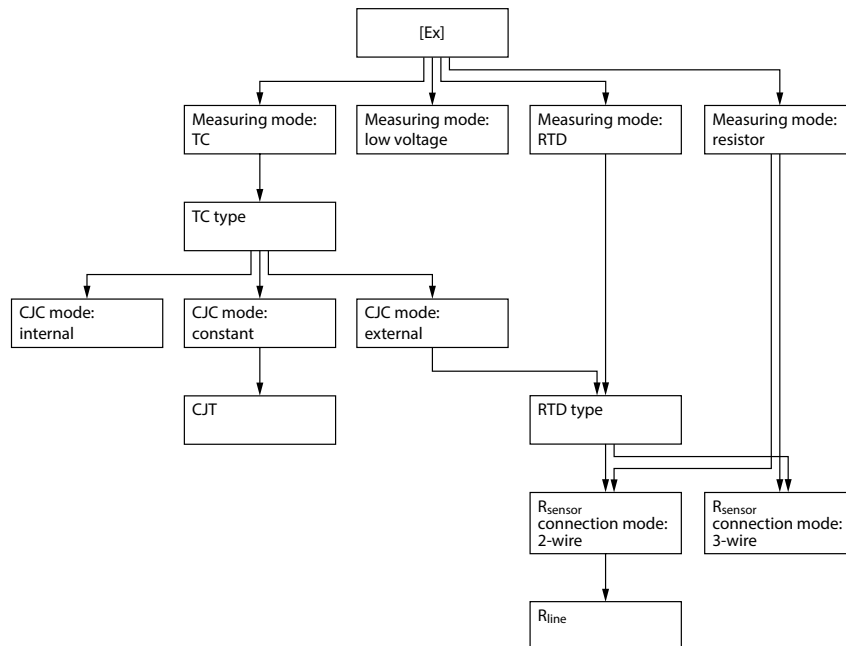

IMX12-TI01-2RTDR-2I
IM12-TI01-2RTDR-2I

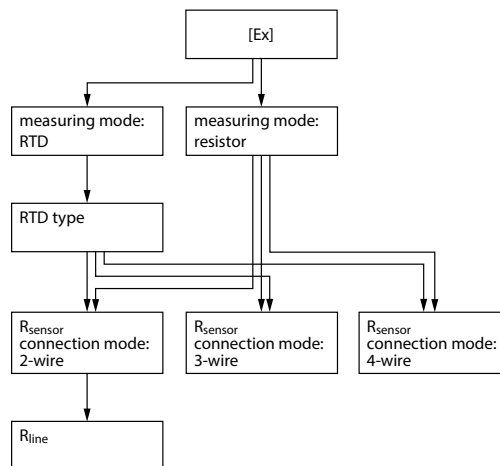

Measuring mode

Input channels [E_x] which are part of a safety function, must not be switched off.

Selection	Description
TC	In Measuring mode Thermocouple the measured value matches the sensor temperature. For this purpose, the TC voltage and the cold junction temperature are measured. With these values the hot junction temperature of the TC is determined according to the sensor characteristic.
resistor	In measuring mode resistor the measuring value matches the input resistance. This depends on the configured R _{Sensor} connection mode.
RTD	In Measuring mode RTD the measured value matches the sensor temperature. For this purpose the sensor resistor is measured. With this value the temperature is determined according to the sensor characteristic.
low voltage	In measuring mode low voltage the measuring value matches the input voltage.

TC type

Selection	Description
DIN EN 60584 Typ A	measuring range 0 °C...1750 °C, min. measuring span 200 K
DIN EN 60584 Typ B	measuring range 0 °C...1750 °C, min. measuring span 200 K
DIN EN 60584 Typ C	measuring range 0 °C...1750 °C, min. measuring span 200 K
DIN EN 60584 Typ E	measuring range -250 °C...1000 °C, min. measuring span 50 K
DIN EN 60584 Typ J	measuring range -210 °C...1200 °C, min. measuring span 50 K
DIN EN 60584 Typ K	measuring range -250 °C...1300 °C, min. measuring span 50 K
DIN EN 60584 Typ N	measuring range -250 °C...1300 °C, min. measuring span 100 K
DIN EN 60584 Typ R	measuring range -50 °C...1750 °C, min. measuring span 200 K
DIN EN 60584 Typ S	measuring range -50 °C...1750 °C, min. measuring span 200 K
DIN EN 60584 Typ T	measuring range -250 °C...400 °C, min. measuring span 50 K
DIN 43710 Typ L	measuring range -200 °C...900 °C, min. measuring span 50 K
GOST 8.585-2001 Typ A-1	measuring range 0 °C...1750 °C, min. measuring span 200 K
GOST 8.585-2001 Typ A-2	measuring range 0 °C...1750 °C, min. measuring span 200 K
GOST 8.585-2001 Typ A-3	measuring range 0 °C...1750 °C, min. measuring span 200 K
GOST 8.585-2001 Typ L	measuring range -200 °C...800 °C, min. measuring span 50 K
GOST 8.585-2001 Typ M	measuring range -200 °C...100 °C, min. measuring span 50 K

CJC mode

Selection	Description
constant	The device can be configured with a constant cold junction temperature (parameter "CJT"). The user must ensure that the cold junction temperature is maintained at this value (e.g. by ice or oven).
internal	If internal cold junction compensation is set, a temperature sensor for sensing the ambient temperature as cold junction temperature is used on the circuit board. The user has to connect the TC directly to the terminals of the device.
external	When external cold junction compensation is set, an external RTD to measure the cold junction temperature is used. The cold junction temperature is measured with an external RTD. The user must measure the RTD temperature at the cold junction of the TC.

CJT

The cold junction temperature in "CJC mode: constant" has a permissible range of -50 °C...100 °C.

RTD type

Selection	Description
DIN EN 60751 Platinum Pt50	measuring range -200 °C...850 °C, min. measuring span 25 K
DIN EN 60751 Platinum Pt100	measuring range -200 °C...850 °C, min. measuring span 25 K
DIN EN 60751 Platinum Pt500	measuring range -200 °C...850 °C, min. measuring span 25 K
DIN EN 60751 Platinum Pt1000	measuring range -200 °C...850 °C, min. measuring span 25 K
DIN 43760 Nickel Ni50	measuring range -60 °C...250 °C, min. measuring span 25 K
DIN 43760 Nickel Ni100	measuring range -60 °C...250 °C, min. measuring span 25 K
DIN 43760 Nickel Ni500	measuring range -60 °C...250 °C, min. measuring span 25 K
DIN 43760 Nickel Ni1000	measuring range -60 °C...250 °C, min. measuring span 25 K
GOST 6651-94 Platinum Pt50	measuring range -200 °C...1100 °C, min. measuring span 25 K
GOST 6651-94 Platinum Pt100	measuring range -200 °C...1100 °C, min. measuring span 25 K
GOST 6651-94 Platinum Pt500	measuring range -200 °C...1100 °C, min. measuring span 25 K
GOST 6651-94 Platinum Pt1000	measuring range -200 °C...1100 °C, min. measuring span 25 K
GOST 6651-94 Copper Cu50	measuring range -50 °C...200 °C, min. measuring span 25 K
GOST 6651-94 Copper Cu53	measuring range -50 °C...200 °C, min. measuring span 25 K
GOST 6651-94 Copper Cu100	measuring range -50 °C...200 °C, min. measuring span 25 K
GOST 6651-94 Copper Cu500	measuring range -50 °C...200 °C, min. measuring span 25 K
GOST 6651-94 Brass CuZn100	measuring range -200 °C...200 °C, min. measuring span 25 K

RSensor connection mode

Selection	Description
2-wire	In the 2-wire connection mode the measured sensor resistance R_{Sensor} is $R_{\text{Sensor}} = R_1 - R_{\text{Line}}$ R_1 : see wiring diagram in „Appendix: Connection and wiring diagrams“ on page 26 R_{Line} : Line resistance. R_{Line} has to be determined by the user. During the configuration this value is set via parameter “ R_{Line} ”. The value is permanently stored in the device.
3-wire	In the 3-wire connection mode the measured sensor resistance R_{Sensor} is $R_{\text{Sensor}} = R_1 - R_2$ R_1, R_2 : see wiring diagram in „Appendix: Connection and wiring diagrams“ on page 26 In the 3-wire measurement, the user must make sure that the current-carrying lines have the same ohmic resistance (balanced line).
4-wire	In the 4-wire connection mode the measured sensor resistance R_{Sensor} is $R_{\text{Sensor}} = R_1$ R_1 : see wiring diagram in „Appendix: Connection and wiring diagrams“ on page 26

RLine

R_{Line} represents the line resistance in “ R_{Sensor} connection mode: 2-wire”. The permissible range is 0 Ω ...50 Ω . The user must ensure that the value of the line resistance does not change.

Analog output

The following figure illustrates the dependence of the parameters. Other parameters are required depending on the previously selected parameters. Selection options for parameters not located on a route marked with arrows are not relevant.

IMX12-TI02-2TCURTDR-2I
IMX12-TI01-2RTDR-2I
IM12-TI02-2TCURTDR-2I
IM12-TI01-2RTDR-2I

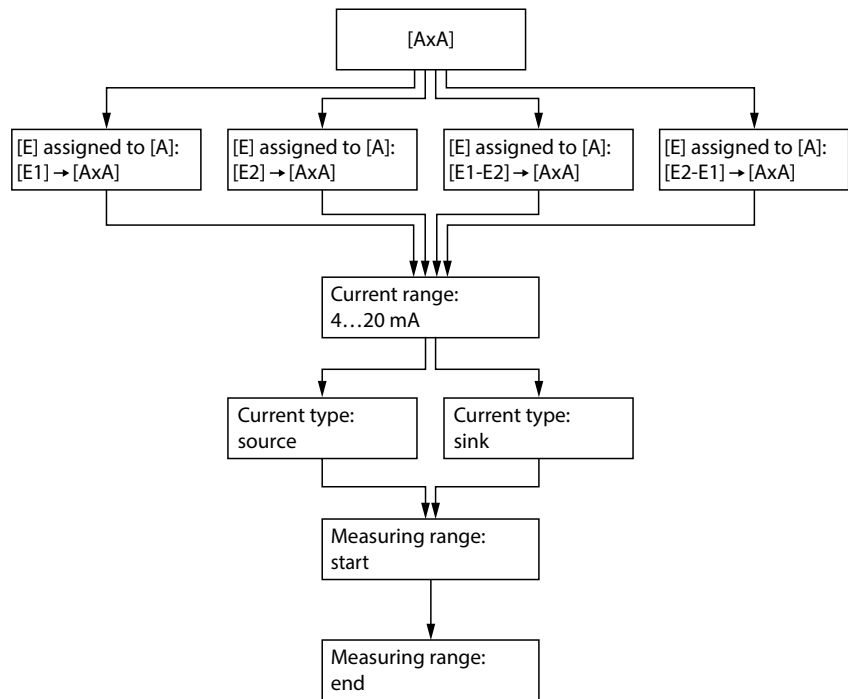

IMX12-TI02-1TCURTDR-1I1R
IM12-TI02-1TCURTDR-1I1R

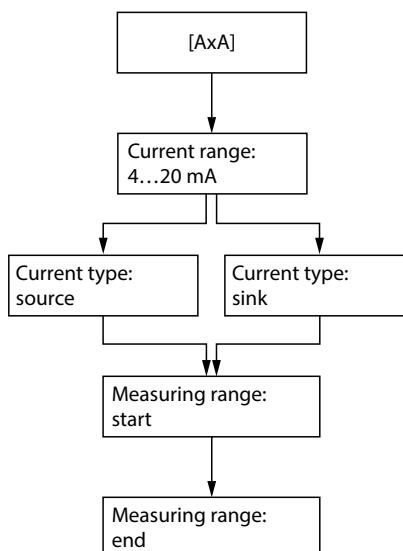

[E_x] assigned to [A_xA]

Selection	Description
[E ₁] → [A ₁ A]	The input [E ₁] is assigned to output [A ₁ A].
[E ₁] → [A ₂ A]	The input [E ₁] is assigned to output [A ₂ A].
[E ₂] → [A ₁ A]	The input [E ₂] is assigned to output [A ₁ A].
[E ₂] → [A ₂ A]	The input [E ₂] is assigned to output [A ₂ A].
[E ₁ - E ₂] → [A ₁ A]	The difference [E ₁ - E ₂] is assigned to output [A ₁ A].
[E ₁ - E ₂] → [A ₂ A]	The difference [E ₁ - E ₂] is assigned to output [A ₂ A].
[E ₂ - E ₁] → [A ₁ A]	The difference [E ₂ - E ₁] is assigned to output [A ₁ A].
[E ₂ - E ₁] → [A ₂ A]	The difference [E ₂ - E ₁] is assigned to output [A ₂ A].

Current range

Selection	Description
4...20 mA	The current output [A _x A] operates in the range 4...20 mA(Live Zero).

Current type

Selection	Description
source	The current output operates as active source.
sink	The current output operates as passive sink.

Measuring range start/end

This parameter defines the start/end value of the measuring range of the analog output. The measuring range start/end must not exceed the measuring range. The span between measuring range start and measuring range end must be equal or higher than the min. measuring span.

Measuring mode	min. measuring range	max. measuring range	min. measuring span
TC	see description TC type	see description TC type	see description TC type
resistor	0 Ω	5000 Ω	3 Ω
RTD	see description RTD type	see description RTD type	see description RTD type
low voltage	-150 mV	150 mV	1 mV

Digital output

The following figure illustrates the dependence of the parameters. Other parameters are required depending on the previously selected parameters. Selection options for parameters not located on a route marked with arrows are not relevant.

IMX12-TI02-1TCURTDR-1I1R
IM12-TI02-1TCURTDR-1I1R

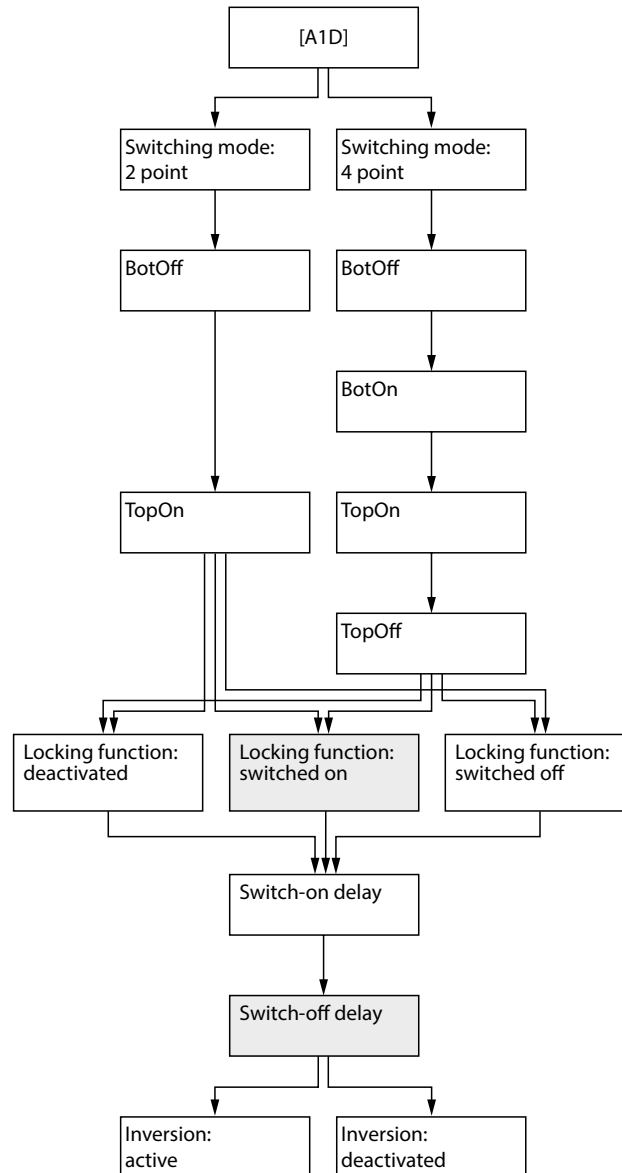

Switching mode

Selection	Description
2-point	<p>In 2-point mode a lower switch point BotOff and an upper switch point TopOn can be defined in the permissible measuring range.</p> <p>The switch points must fulfill the following condition:</p> <ul style="list-style-type: none"> - BotOff ≤ TopOn - The hysteresis can be 0 <p>The switching behavior depends on parameter "inversion".</p> <p>The following figure shows the switching behavior when inversion is deactivated:</p>

4-point	<p>In 4-point mode a window with a lower and upper hysteresis is formed.</p> <p>The switch points must fulfill the following condition:</p> <ul style="list-style-type: none"> - BotOff ≤ BotOn < TopOn ≤ TopOff - The hysteresis can be 0 <p>The switching behavior depends on parameter "inversion".</p> <p>The following figure shows the switching behavior when inversion is deactivated:</p>
---------	---

BotOn/BotOff/TopOn/TopOff

These parameters represent the switching threshold for 2-point and 4-point switching modes. The switching thresholds must not exceed the measuring range.

Measuring mode	min. measuring range	max. measuring range
TC	see description TC type	see description TC type
resistor	0 Ω	5000 Ω
RTD	see description RTD type	see description RTD type
low voltage	-150 mV	150 mV

Locking function

This parameter depends on the physical state of the relay. Parameter "Inversion" is regarded.

Selection	Description
deactivated	In this selection the relay switches on and off corresponding to the measured value and selected configuration.
switched on	The relay switches on according to the measured value and selected configuration. It stays permanently locked on. The locked state is left after power on reset or detection of a failure.
switched off	The relay switches off according to the measured value and selected configuration. It stays permanently locked off. The locked state is left after power on reset.

Switching on/off delay

The value of this parameter specifies the switch on/off delay after detection of of switch on/off condition.

Values between 0.0...999.9 s are possible.

Inversion

Selection	Description
activated	This function enables the inversion of the switching state (instead of off, on and vice versa)
deactivated	If the Inversion function is disabled, the switching state is transferred to the digital output A1D without inversion according to the parameter setting.

6.3.3 Parameter-Check

- Before the verification of the parameterization PC-Connect must be disconnected and the device must be reset.
- The proof test (see „10 Appendix: Proof tests“ on page 32) shall be executed in order to check the requested function and parameterization.
- The tests shall be executed even if the device was not parameterized.
- Within the proof tests each relevant parameter shall be checked for correct function.
- The device shall be locked against unintended operation/modification.
- The device must not parameterized during operation.
- The proof test shall be documented.

6.4 Operation

- ▶ If the device is used in low demand mode, proof tests shall be executed periodically according to T1 (see „10 Appendix: Proof tests“ on page 32).
- ▶ Ensure that the plug connections and cables are always in good condition.
- ▶ The device must be replaced immediately if the terminals are faulty or the device has any visible faults.
- ▶ If cleaning is required, do not use any liquid or statically charging cleaning agent. Perform proof tests after each cleaning (see „10 Appendix: Proof tests“ on page 32).

6.5 After operation

- ▶ Undo the terminal connection on the device.
- ▶ Remove the device from its rail fixing as shown in the figure:

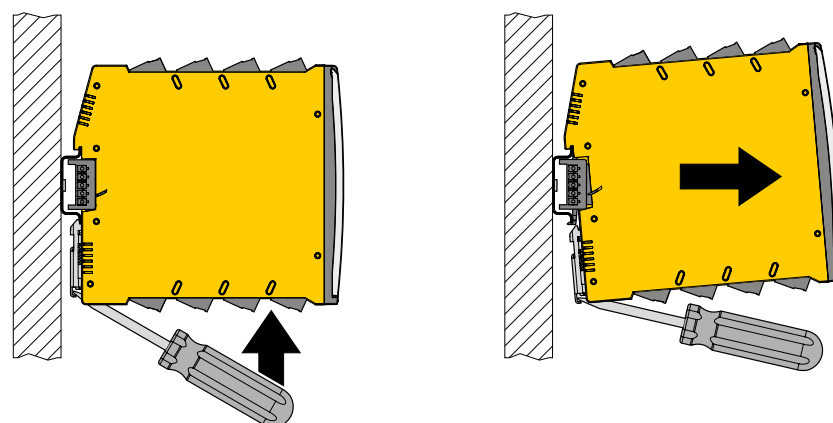

Fig. 4: Remove device

- ▶ Ensure the proper disposal of the device.

7 Appendix: Connection and wiring diagrams

The pin number assignment can be found at the front label.
 Load resistance is (A1, A2): $\leq 800 \Omega$

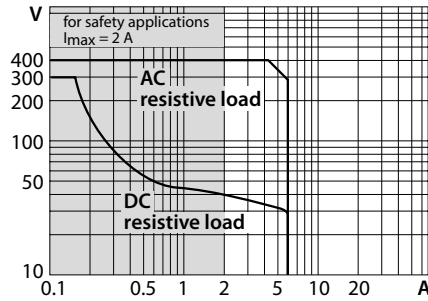

Fig. 5: Load Curve

The connection of a deactivated input is unnecessary.

IMX12-TI01-2RTDR-2I

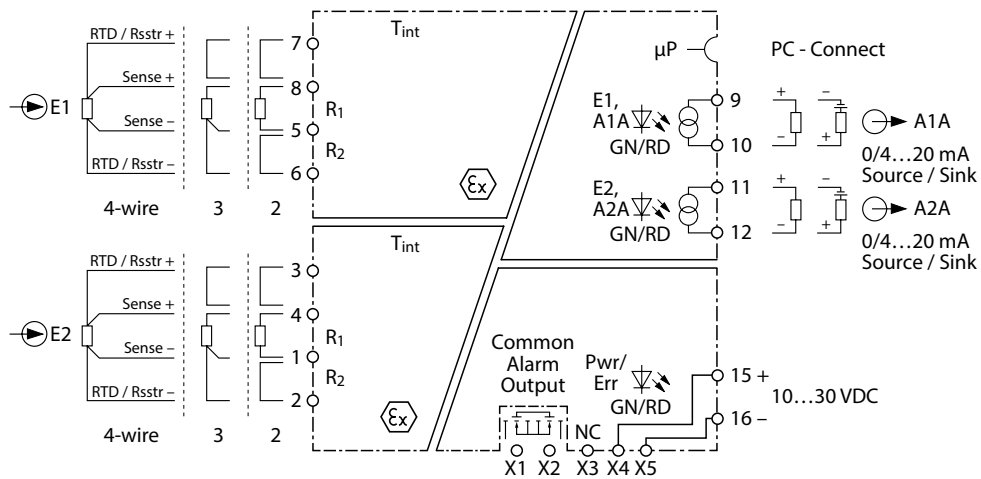

Fig. 6: IMX12-TI01-2RTDR-2

IM12-TI01-2RTDR-2I

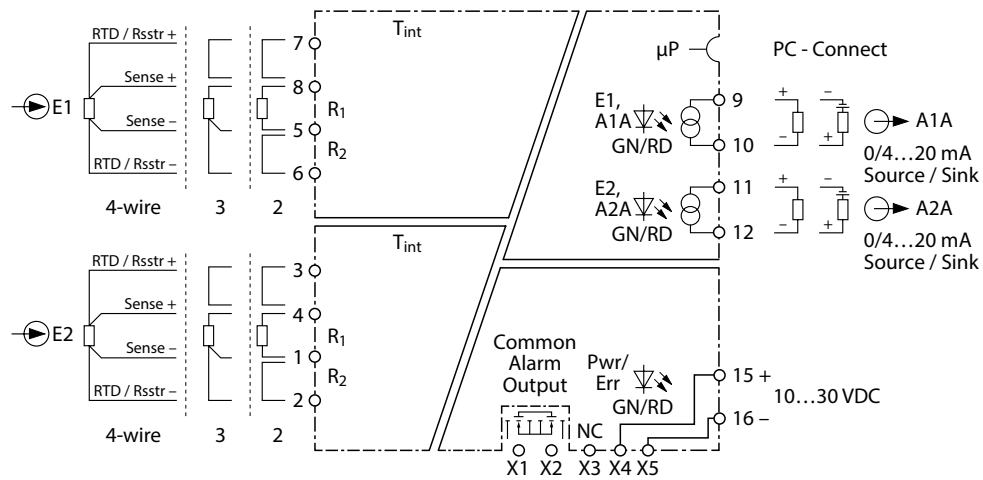

Fig. 7: IM12-TI01-2RTDR-2I

IMX12-TI02-2TCURTDR-2I

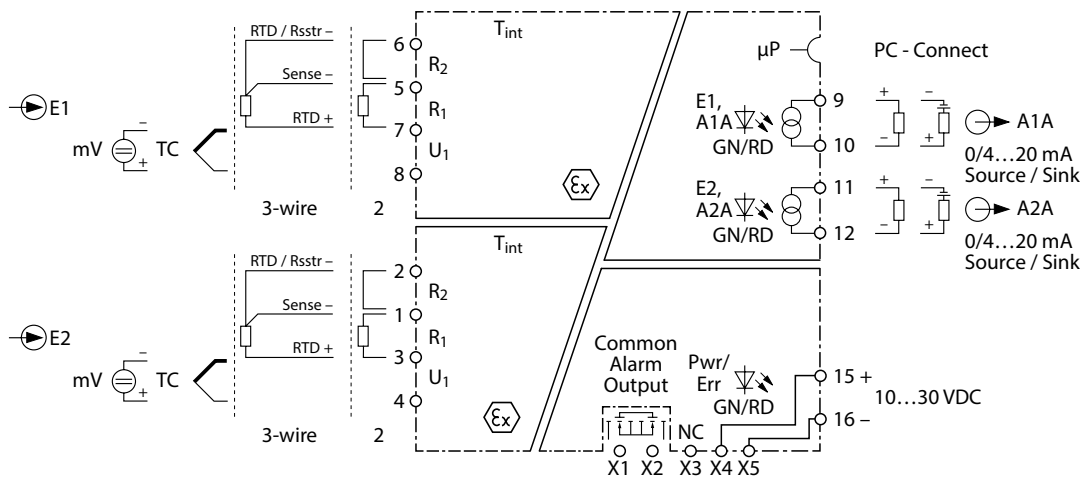

Fig. 8: IMX12-TI02-2TCURTDR-2I

IM12-TI02-2TCURTDR-2I

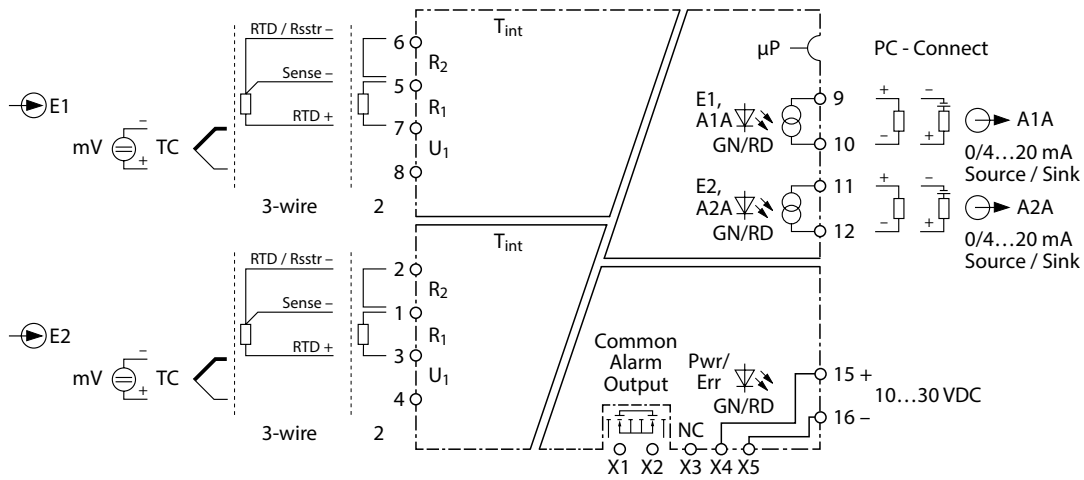

Fig. 9: IM12-TI02-2TCURTDR-2I

IMX12-TI02-1CURTDR-1I1R

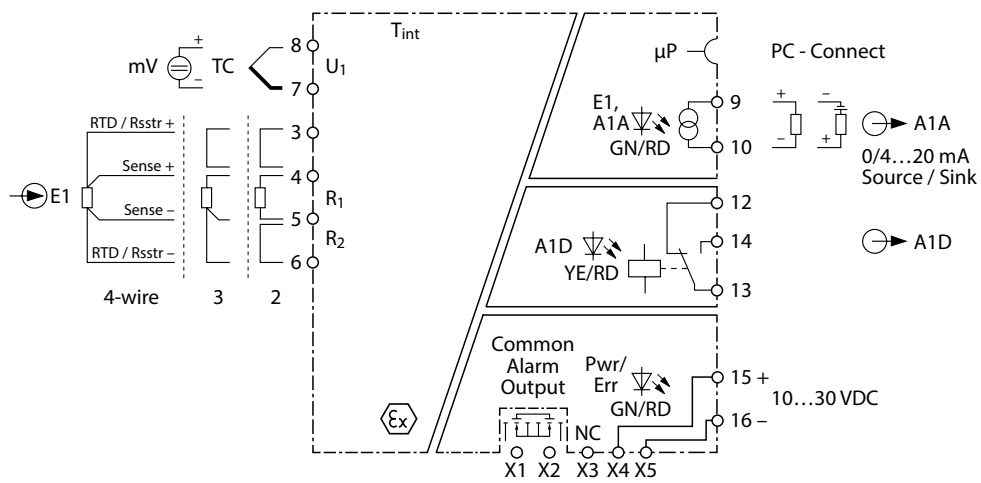

Fig. 10: IMX12-TI02-1CURTDR-1I1R

IM12-TI02-1TCURTDR-1I1R

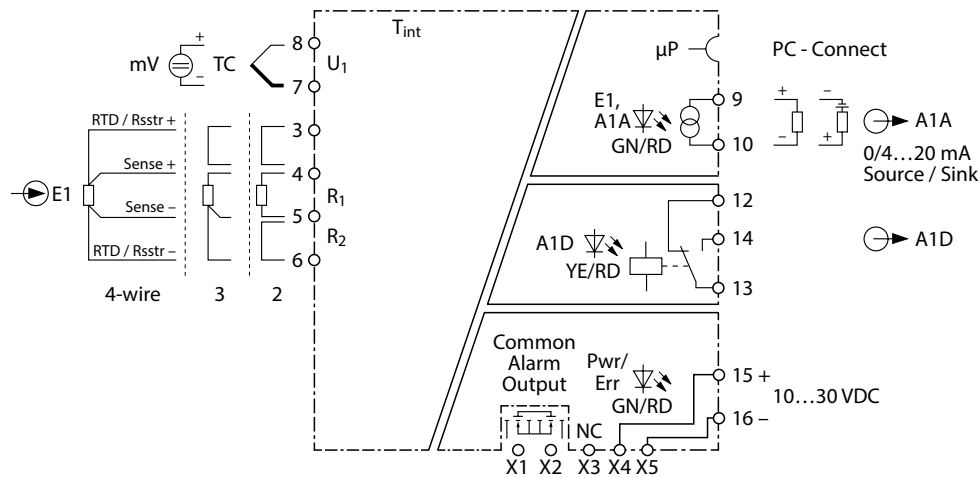

Fig. 11: IM12-TI02-1TCURTDR-1I1R

8 Appendix: Terms and abbreviations

DC	Diagnostic Coverage
FIT	1 FIT is 1 failure per 10E09 hours
FMEDA	Failure Modes, Effects and Diagnostic Analysis
HFT	Hardware failure tolerance
λ_{AU}	Undetected Annunciation failure rate (per hour) Annunciation failures do not directly impact safety but impact the ability to detect a future fault (such as a fault in diagnostic circuit).
λ_{DD}	Detected dangerous failure rate (per hour)
λ_{DU}	Undetected dangerous failure rate (per hour)
λ_{SD}	Detected safe failure rate (per hour)
λ_{SU}	Undetected safe failure rate (per hour)
MTTR	Mean time to restoration (hour)
PFD_{avg}	Average probability of failure on demand
PFH	Probability of dangerous failure per hour
SFF	Safe Failure Fraction
SIL	Safety Integrity Level
T_1	Proof test interval (hour)
Type A	"Non-complex" element (all failure modes are well defined); for details see 7.4.4.1.2 of IEC 61508-2
Type B	"Complex" element (using micro controllers or programmable logic); for details see 7.4.4.1.3 of IEC 61508-2

9 Appendix: Failures

9.1 Resistance

	Δ_{Ohm}
Low Range 0...500 Ω	0,2 Ω
High Range 500...5000 Ω	2 Ω

When selecting "R_{Sensor} connection mode: 3-wire" the value for Δ_{Ohm} are doubled.

9.2 TC

TC Type	Δ_{TC}
DIN EN 60584 Typ A	15 K
DIN EN 60584 Typ B	199 K
DIN EN 60584 Typ C	13 K
DIN EN 60584 Typ E	15 K
DIN EN 60584 Typ J	9 K
DIN EN 60584 Typ K	24 K
DIN EN 60584 Typ N	34 K
DIN EN 60584 Typ R	41 K
DIN EN 60584 Typ S	39 K
DIN EN 60584 Typ T	21 K
DIN 43710 Typ L	6 K
GOST 8.585-2001 Typ A-1	15 K
GOST 8.585-2001 Typ A-2	15 K
GOST 8.585-2001 Typ A-3	15 K
GOST 8.585-2001 Typ L	7 K
GOST 8.585-2001 Typ M	10 K

9.3 RTD

RTD-Type	Δ_{RTD}
DIN EN 60751 Platinum Pt50 DIN EN 60751 Platinum Pt500	1,4 K
DIN EN 60751 Platinum Pt100 DIN EN 60751 Platinum Pt1000	0,8 K
DIN 43760 Nickel Ni50 DIN 43760 Nickel Ni500	0,9 K
DIN 43760 Nickel Ni100 DIN 43760 Nickel Ni1000	0,5 K
GOST 6651-94 Platinum Pt50 GOST 6651-94 Platinum Pt500	1,5 K
GOST 6651-94 Platinum Pt100 GOST 6651-94 Platinum Pt1000	0,5 K
GOST 6651-94 Copper Cu50 GOST 6651-94 Copper Cu500	1 K
GOST 6651-94 Copper Cu53	0,9 K
GOST 6651-94 Copper Cu100	0,5 K
GOST 6651-94 Brass CuZn100	0,5 K

When selecting "R_{Sensor} connection mode: 3-wire" the value for Δ_{RTD} are doubled.

10 Appendix: Proof tests

Proof tests shall be undertaken to reveal dangerous faults which are undetected by diagnostic tests. This means that it is necessary to specify how dangerous undetected faults which have been noted during the FMEDA can be detected during proof testing.

Ensure that the proof test is only carried out by qualified personnel.

A suggested proof test consists of the following steps:

Step	Action
1.	Bypass the safety functions and take appropriate action to avoid a false trip.
2.	Provide appropriate input-/control signals to the interface modules and verify the expected signal input/output conditions for the interfaces.
3.	Verify if internal fault detection is working in case it is activated.
4.	Provide appropriate input-/control signals to the interface modules and verify that the safety function is carried out correctly.
5.	Remove the bypass and otherwise restore normal operation.

This test will detect 97 % of possible dangerous undetected failures.
Once the test has been completed, document and archive the results.

11 Appendix: Document history

Document Version	Modifications
1.0	Initial version
2.0	<ul style="list-style-type: none"> - useful lifetime update - assumption constant failure rates „for 10 years“ added - „Before expiration of the useful lifetime the device must be replaced.“ deleted - cable ends reduced to 7mm - headings low-/high-demand updated
3.0	<ul style="list-style-type: none"> - Ambient temperature specified more precisely - Factor 2.5 for 60°C ambient temperature added - Application SN29500 specified
4.0	<ul style="list-style-type: none"> - IM (non-X) devices added - headings low-/high demand updated - note for variants added: power-rail is safety-related - note for 61326-3-1 modified: exceed (not increase) - power rail renamed in power bridge - cage clamps renamed in spring type - in chapter 2 Intrinsic Safety added - slight modifications of FIT values due to recalculation with corresponding changes in PFD and PFH
5.0	SIL card removed

12 Appendix: Certificate

The certificate can be found on the internet at www.turck.com.

TURCK

Your Global Automation Partner

Over 30 subsidiaries and
60 representations worldwide!

D201487 | 2026/01



www.turck.com